

SR-1417
 1.7 MILES EAST OF SR-1416
 092013

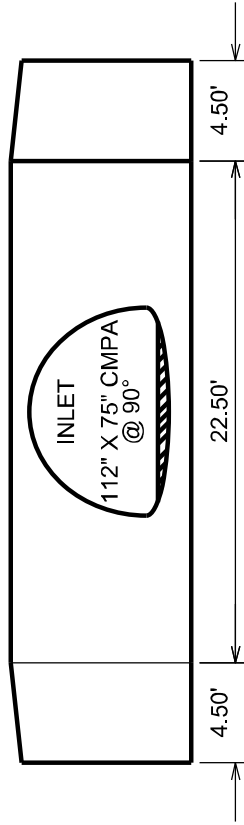

- ← TOP OF WALL - 99.5'
- ← TAPER - 99.0'
- ← TOP OF BAFFLE - 92.5'
- ← INLET INVERT - 92.0'
- ← BOTTOM OF WALL - 91.0'

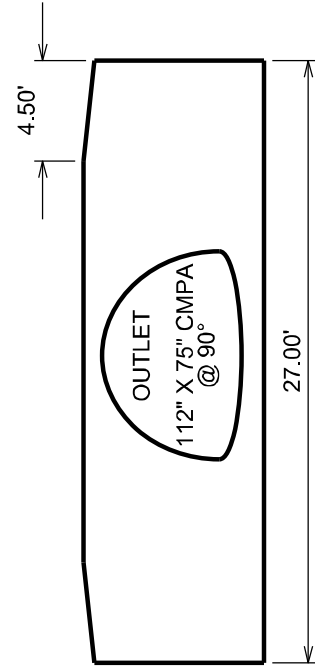

- ← TOP OF WALL - 99.5'
- ← TAPER - 99.0'
- ← OUTLET INVERT - 91.5'
- ← BOTTOM OF WALL - 90.5'

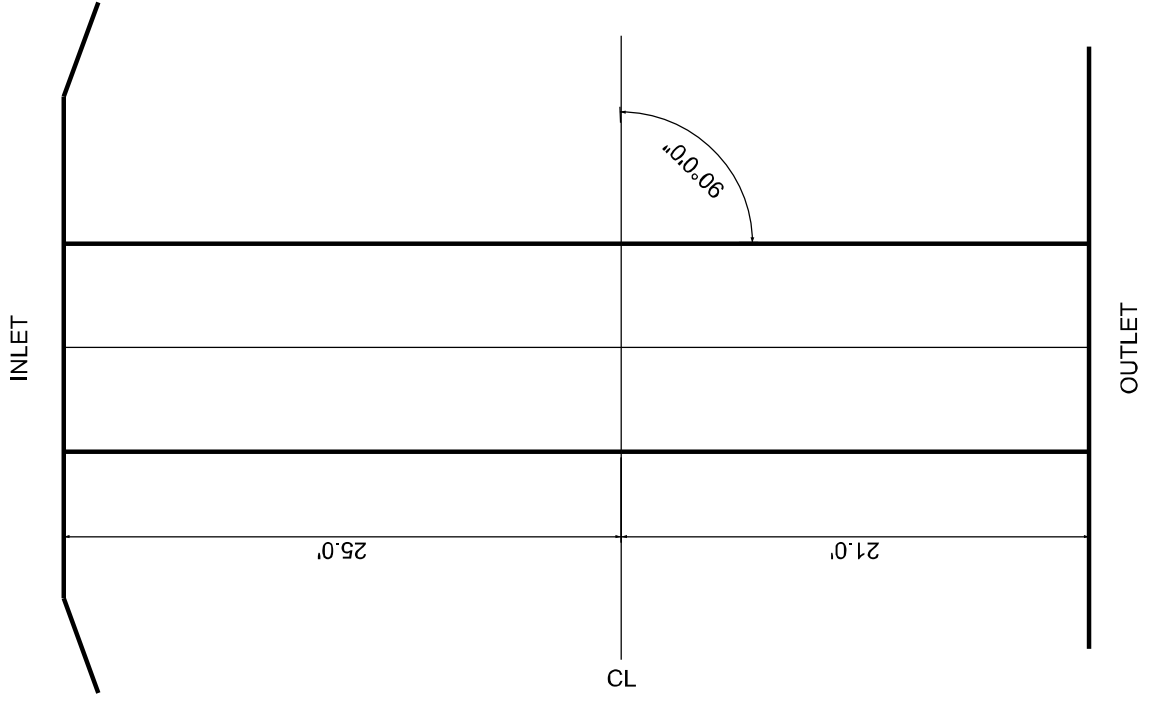

SR-1308
 0.9 MILES WEST OF NC 904
 092041

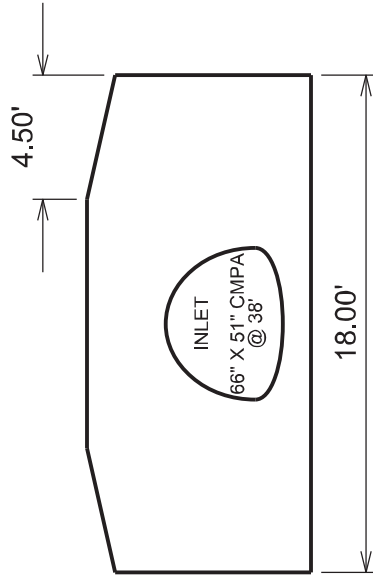

TOP OF WALL - 99.39'
 TAPER - 98.39'

INLET INVERT - 92.9'
 BOTTOM OF WALL - 91.9'

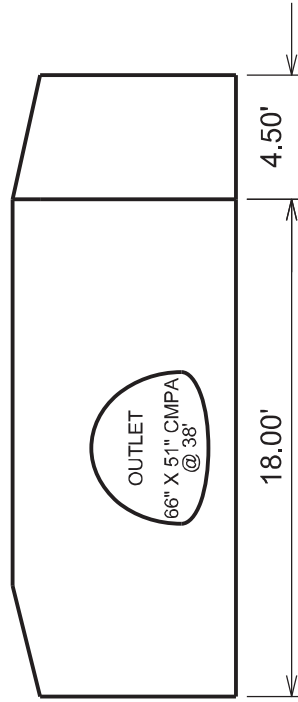

TOP OF WALL - 99.5'
 TAPER - 98.5'

OUTLET INVERT - 91.9'
 BOTTOM OF WALL - 90.9'

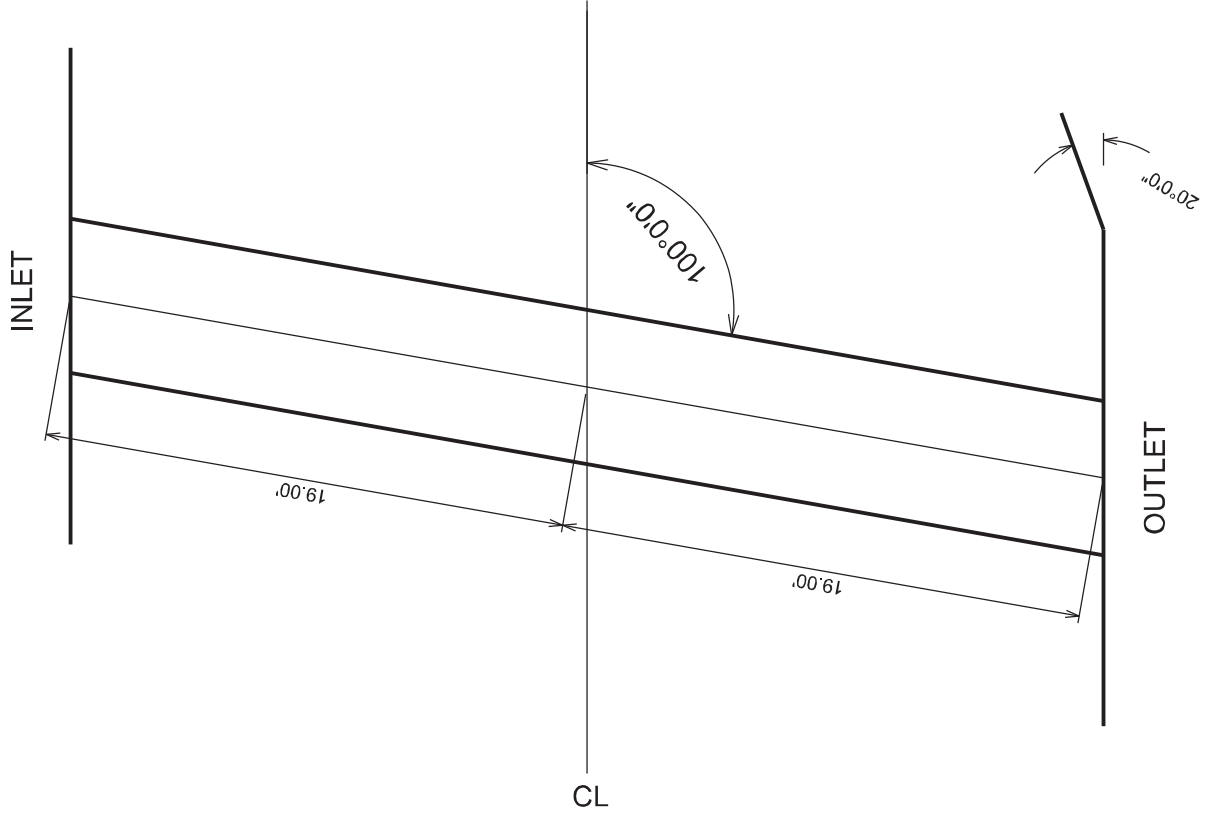

SR-1513 0.8 MILES EAST OF US 17 BUS. 092043

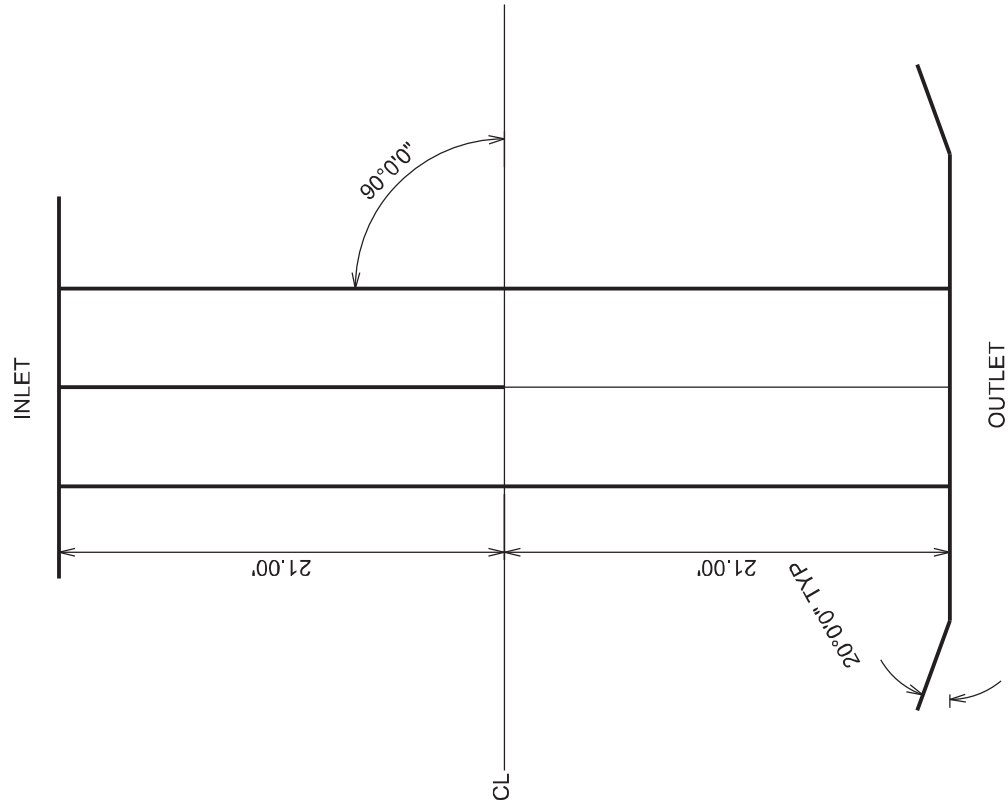
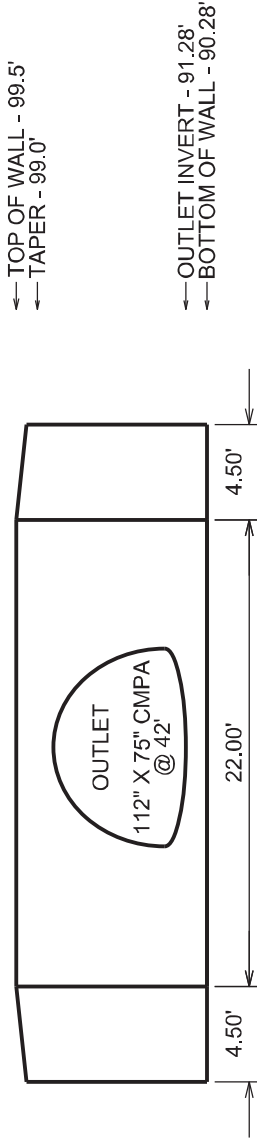
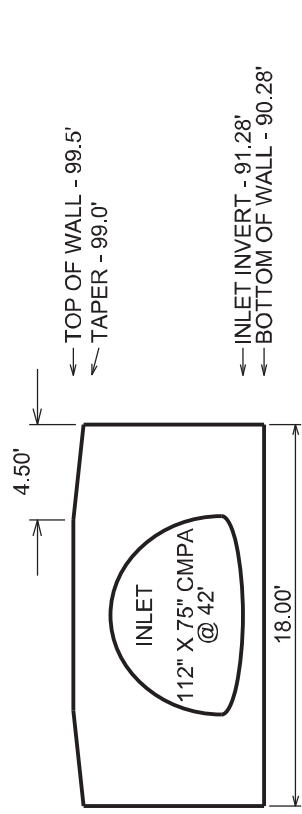

NC 904
 0.8 MILES SOUTH OF US 17
 092055

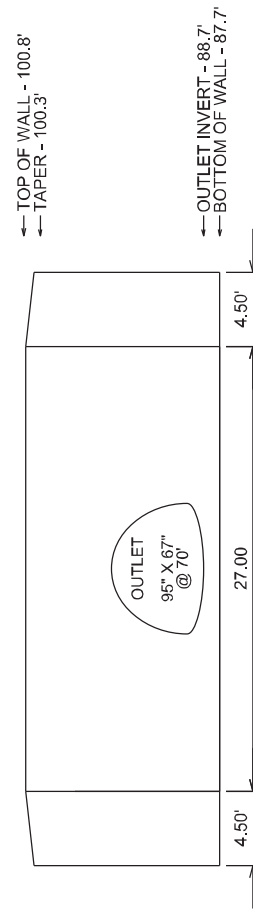
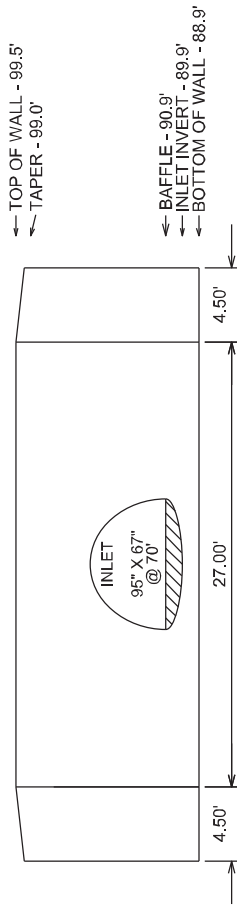
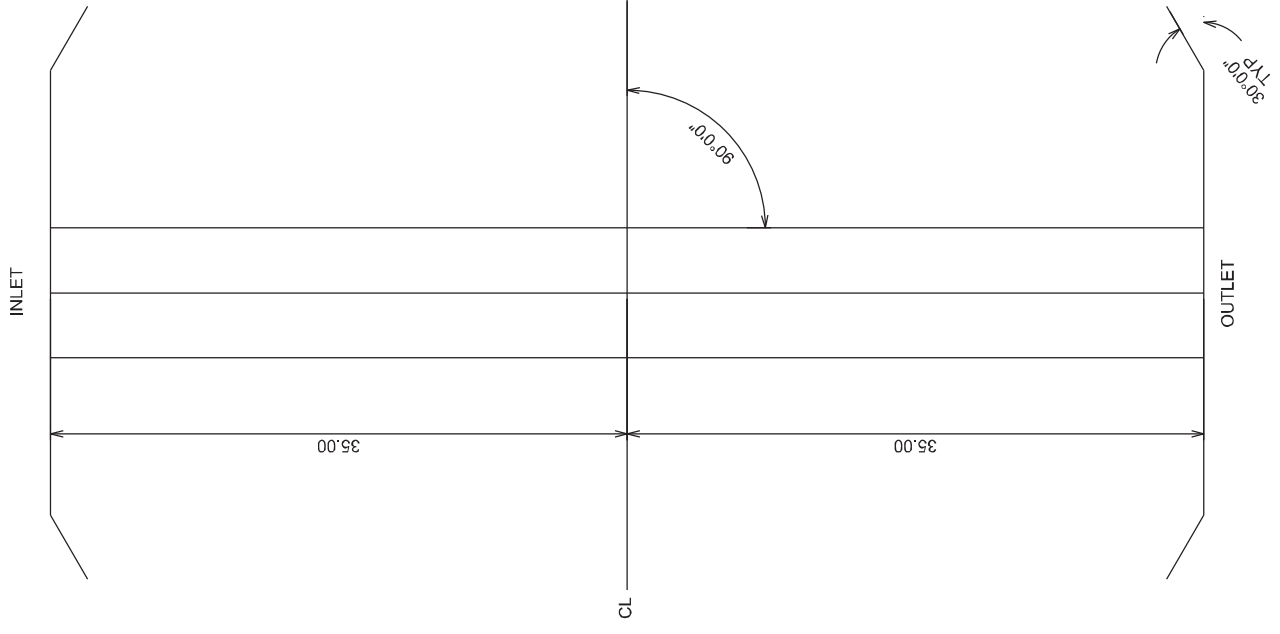

SR-1119
 0.1 MILES NORTH OF SR-1128
 092127

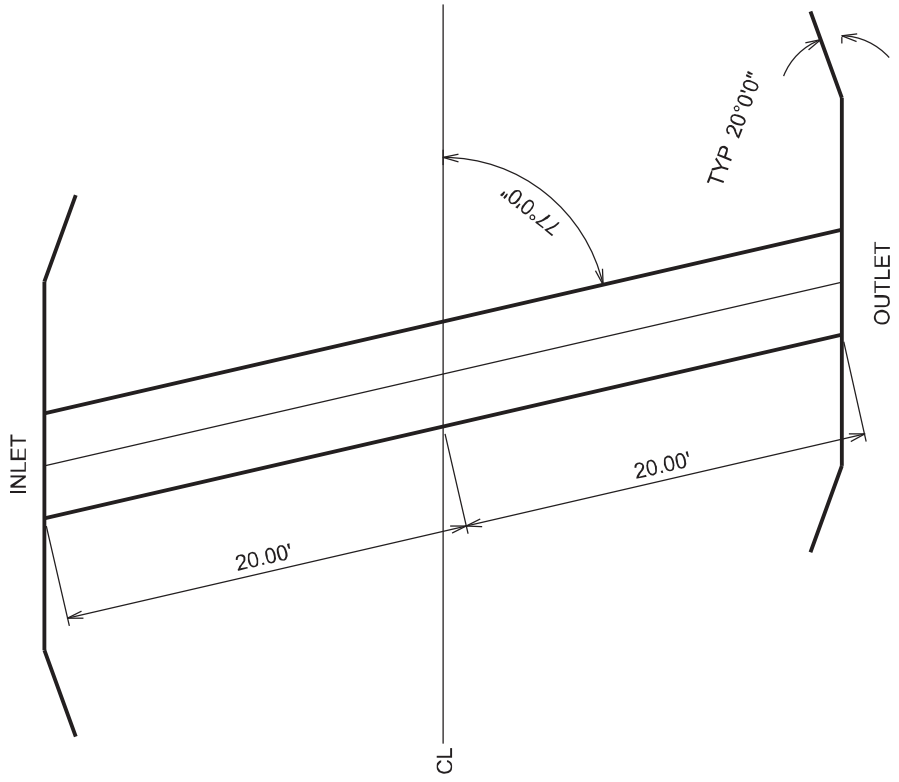

← TOP OF WALL - 98.97'
 ← TAPER - 98.3'

← INLET INVERT - 91.5'
 ← BOTTOM OF WALL - 90.5'

← TOP OF WALL - 99.5'
 ← TAPER - 99.0'

← OUTLET INVERT - 91.1'
 ← BOTTOM OF WALL - 90.1'

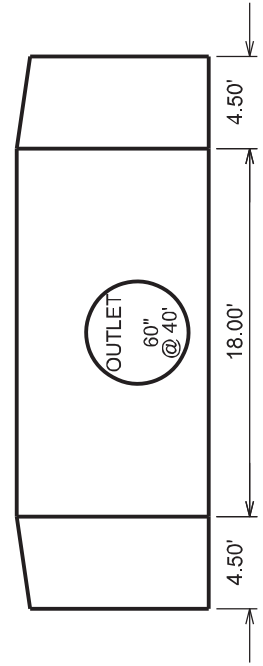
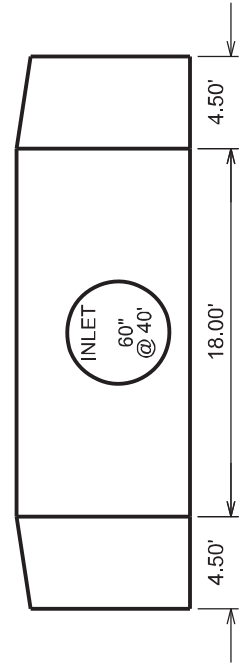

SR-1128 0.3 MILES EAST OF SR-1119 092128

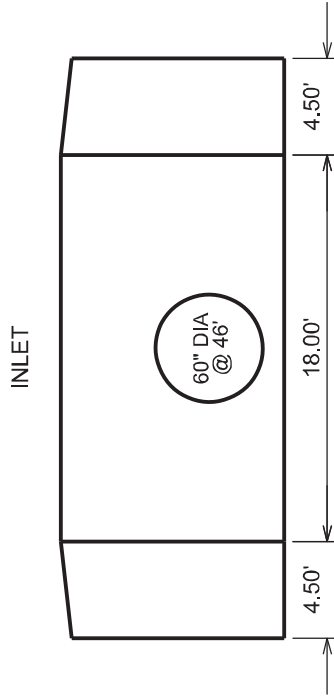
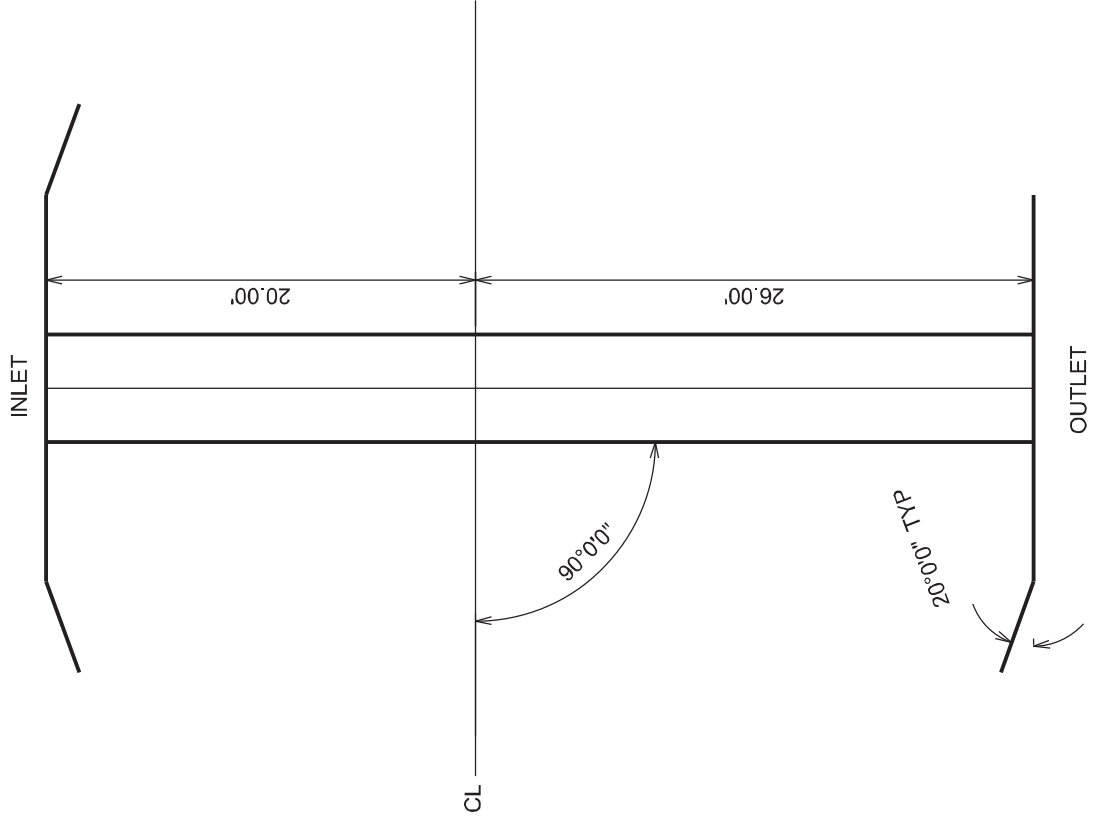

TOP OF WALL - 99.5'
TAPER - 99.0'

INLET INVERT - 90.1'
BOTTOM OF WALL - 89.1'

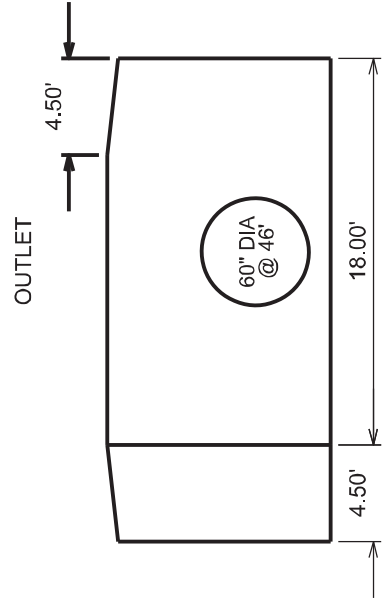

TOP OF WALL - 99.5'
TAPER - 99.0'

OUTLET INVERT - 89.8'
BOTTOM OF WALL - 89.3'